

ROUGH COUNTRY

GM 2019-23 1500 / 2020-24 HD CREW CAB HD2 STEP

Thank you for choosing Rough Country for all your vehicle needs.

Please read instructions before beginning installation. Check the kit hardware against the kit contents shown below.

Be sure you have all needed parts and know where they go. If question exist, please call us @1-800-222-7023. We will be happy to answer any questions concerning this product.

Check all fasteners for proper torque. Check to ensure for adequate clearance between all components. Periodically check all hardware for tightness.



Torque Specs:

Size	Grade 5	Grade 8	Size	Class 8.8	Class 10.9
5/16"	15 ft/lbs	20ft/lbs	6MM	5ft/lbs	9ft/lbs
3/8"	30 ft/lbs	35ft/lbs	8MM	18ft/lbs	23ft/lbs
7/16"	45 ft/lbs	60ft/lbs	10MM	32ft/lbs	45ft/lbs
1/2"	65 ft/lbs	90ft/lbs	12MM	55ft/lbs	75ft/lbs
9/16"	95 ft/lbs	130ft/lbs	14MM	85ft/lbs	120ft/lbs
5/8"	135ft/lbs	175ft/lbs	16MM	130ft/lbs	165ft/lbs
3/4"	185ft/lbs	280ft/lbs	18MM	170ft/lbs	240ft/lbs



Required Installation Parts and Fasteners Included

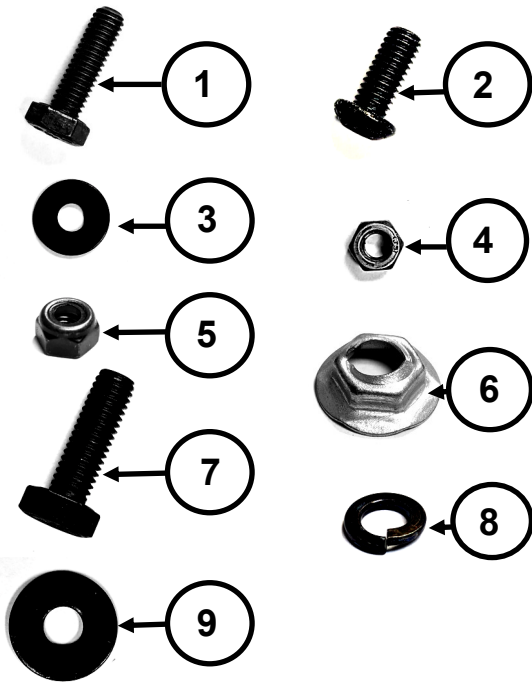

ITEM	QTY.	DESCRIPTION
1	16	M6 X 20MM. HEX BOLT
2	8	M6 X 15MM. BUTTON HEAD BOLT
3	16	M6 FLAT WASHER
4	8	M6 HEX NUT
5	16	M6 LOCK NUT
6	24	M8 SELF THREADING NUT
7	16	M8 X 25MM HEX BOLT
8	8	M6 LOCK WASHER
9	16	M8 OVERSIZE WASHER
10	6	STEP BRACKET
11	2	REAR STEP BRACKET (D&P)
12	4	END CAPS (2 FRONT & 2 RR)
13	4	TREAD-PLATE
14	2	STEP RAILS

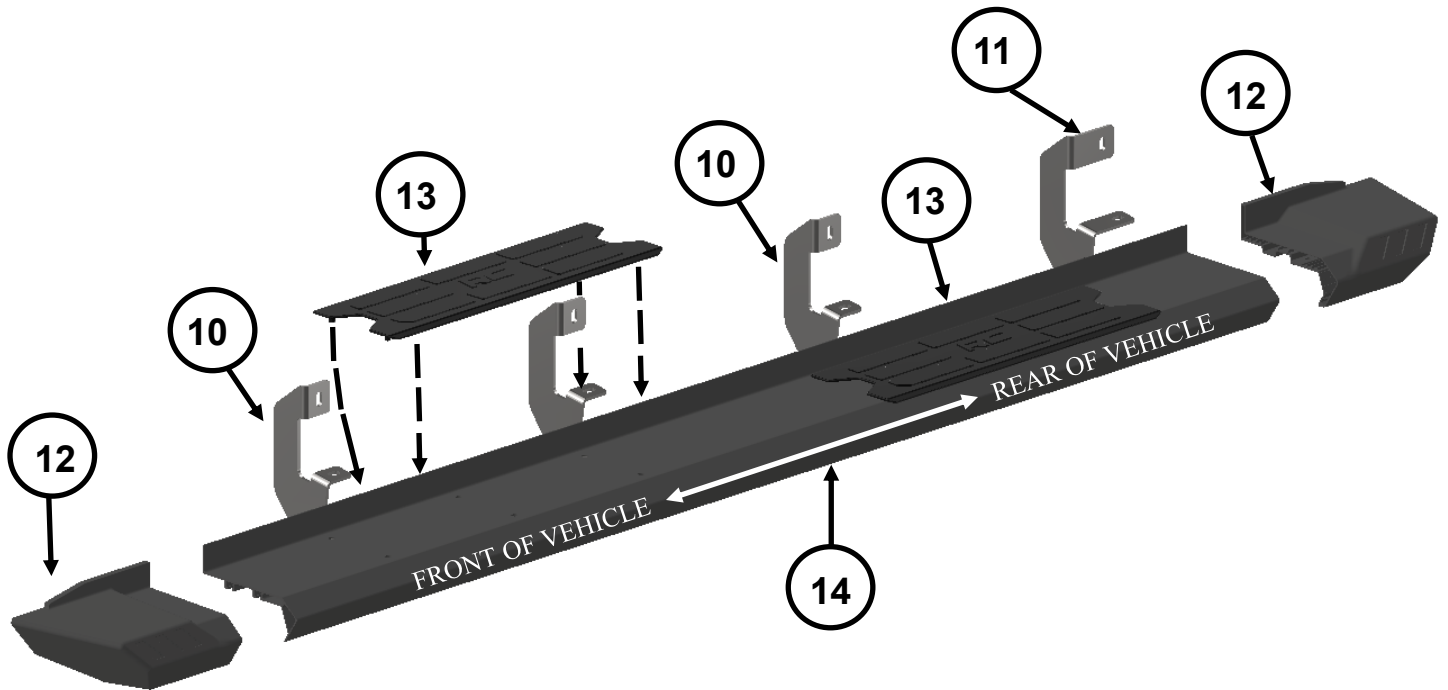

TOOLS NEEDED FOR INSTALLATION:

- COMMON SENSE
- 10MM SOCKET AND OR WRENCH
- 13MM SOCKET AND OR WRENCH
- 1 CASE OF YOUR BEVERAGE OF CHOICE



HD2 BOARD ASSEMBLY

HD2 Board Assembly Inventory (reference part index on the previous page): Qty 12 Self Threading Nut (6), Qty 1 Step Rail (13), Qty 2 Tread-Plates (12), Qty 8 M6 Hex Bolts (1), M6 Hex Nut (4), Qty 2 End Caps (11), Qty 4 M6 Button Head Bolt (2). *(Quantities of hardware used are for assembly of one step rail.)*

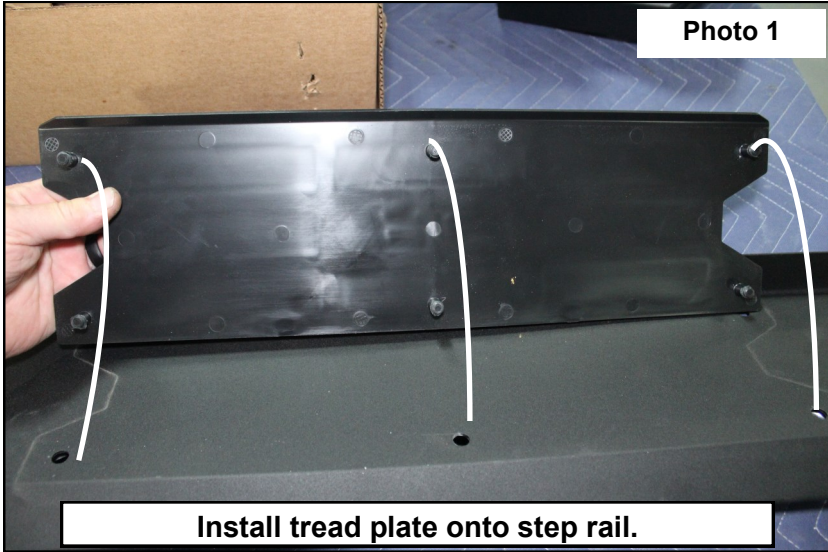

Step 1: Place the molded tread-plate onto the running board aligning the pegs with the holes in the step board **(Photo 1)**. These pegs will protrude through the step board. The self threading nuts will then be used to secure the tread-plate onto the step board.

Step 2: Secure the tread plate to the step board with the supplied self-threading nut using a 13mm socket **(Photos 2 & 3)**. * Remember these fasteners are cutting threads. Tighten slowly with a 13mm socket.

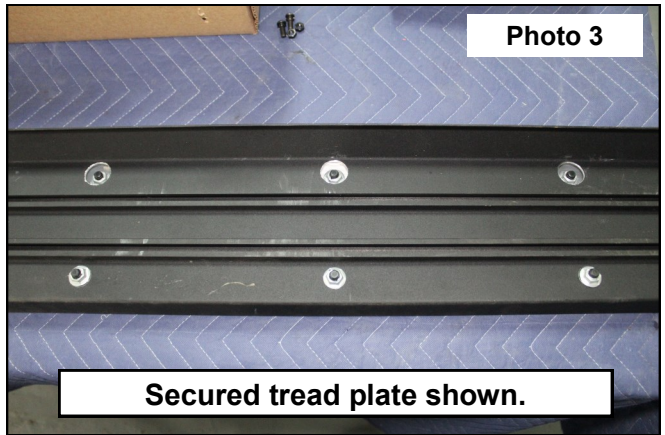
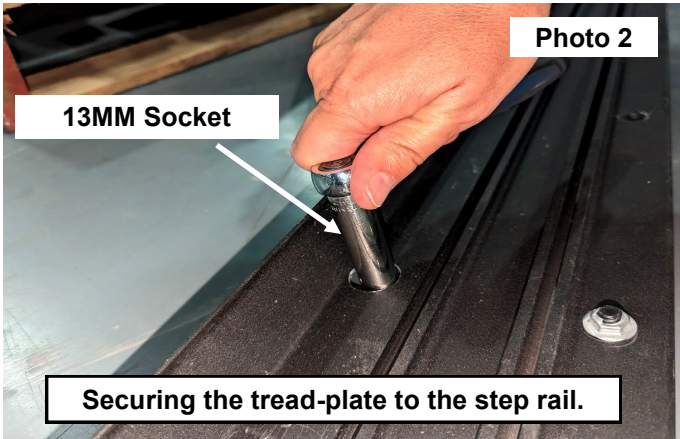

Step 3: Slide qty 4 of the 6MM Hex bolts in to **both** T-slots on the bottom side of the step rail. These will be used later to attach the step rail to the provided step brackets **(Photo 5 & 6)**.

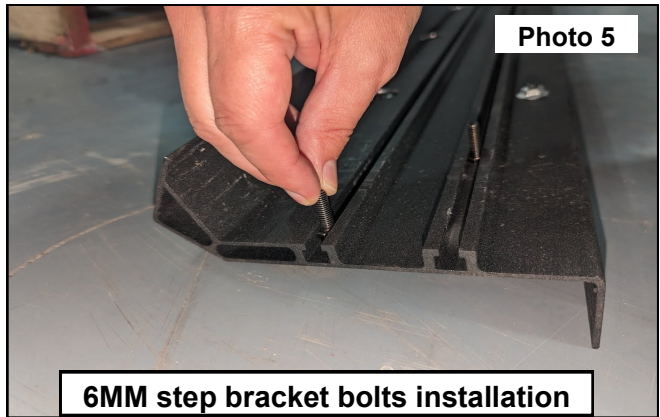
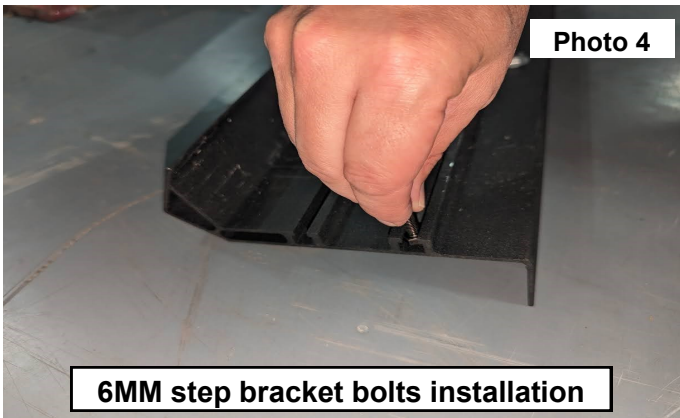

Step 5: Place (2) 6mm finish nuts into the T-rail on the underside of the step board. Use (2) supplied 6mm lock washers and button head bolts to secure the endcap to the step board. Tighten with a 4mm Allen wrench. **See Photo 6 & 7.** Repeat these steps to assemble the other step board.

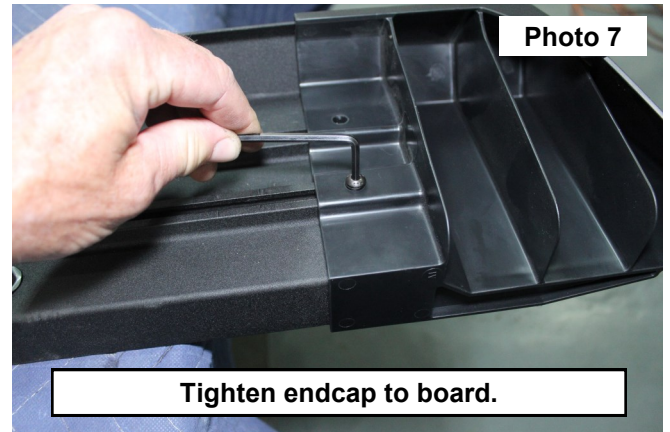
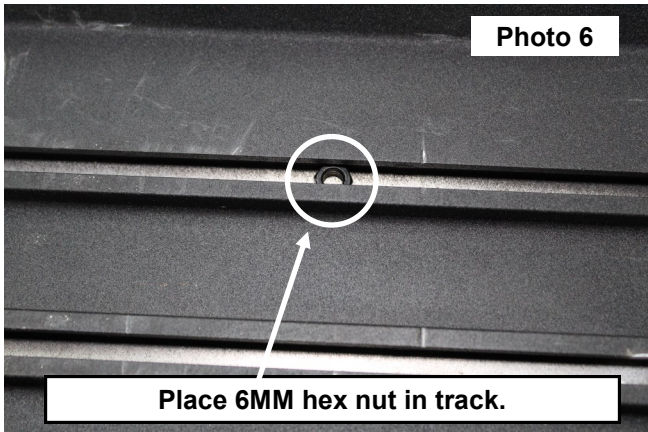

SANITY CHECK: Before moving to installation, the following should be complete. All four tread plates are fastened, Qty 3 of the 6MM hex bolts are in each of the T-slot rails, and the end caps are bolted into place? If the answer is **YES** to all of these, proceed to vehicle installation. If you answered **NO** to any of these, stop drinking and call a friend to help, or find a local installer to correct your mistakes.

VEHICLE INSTALLATION OF STEPS

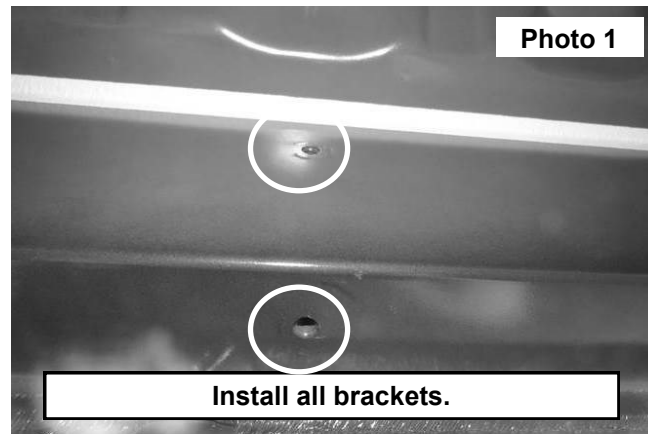

Step 1: Locate the threaded factory mounting holes in the rocker panel of the vehicle. If your truck did not come with factory steps, be prepared to remove plastic plugs protecting the threaded holes (**see Photo 1**).

Step 2: Install all brackets using the supplied 8mm oversize washer and bolt. Use a 13mm wrench/socket to tighten (**see Photo 2**).

Step 3: Align the bolts in the track of the assembled step boards with the slots of the brackets. Use the supplied 6mm washer and lock nut to secure. Use a 10mm wrench to tighten (**see photo 4**). Repeat steps 1-3 for opposite side.



By purchasing any item sold by Rough Country, LLC, the buyer expressly warrants that he/she is in compliance with all applicable, State, and Local laws and regulations regarding the purchase, ownership, and use of the item. It shall be the buyers responsibility to comply with all Federal, State and Local laws governing the sales of any items listed, illustrated or sold. The buyer expressly agrees to indemnify and hold harmless Rough Country, LLC for all claims resulting directly or indirectly from the purchase, ownership, or use of the items.

